



SERIES: VP-P

PATENTED

INTERCHANGE: Stucchi internal specification

MAIN APPLICATIONS

- Mobile construction equipment
- Hydraulic equipment
- Drilling rigs
- Vehicles

The "VP-P" screw flat face coupling series is the technological solution to demanding hydraulic applications.

The screw connection system eliminates premature wear and the "brinelling" caused by a mechanical locking ball system.

This makes the "VP-P" series suitable for high operating and impulse pressures.

The triple valve system allows connection of the coupling safely even in presence of high internal residual pressure and at the same time avoiding fluid loss. The safety sleeve integrated in the connection system prevents accidental disconnection making the "VP-P" series ideal for the most extreme operating conditions where strong vibration and torsion issues are present.



Stucchi[®]

A CONSTANT FLOW OF SOLUTIONS

TECHNICAL FEATURES AND OPTIONS

- Interchangeability: Stucchi internal specification
- Valve system: Flat face
- Mechanical connection: Screw system
- Connection system: Screw to connect
- Disconnection system: Unscrew to connect
- Connection with residual pressure: Allowed in the male coupling, female coupling or both.
- Disconnection with residual pressure: Allowed
- Threads available: BSP, NPT, SAE
- Threads on request: Metrics DIN, ORFS or others
- Construction material: High grade carbon steel.
Threaded zone treatment: nitriding + oxidation (QPQ)
- Other Surface treatment: Zinc plated
- External springs: AISI 302
- Internal springs: C72 steel
- Balls: Hard steel 100 C6
- Seals: standard in NBR (Nitrile), PUR (Polyurethane), POM (Delrin)
- Anti-extrusion rings: PTFE

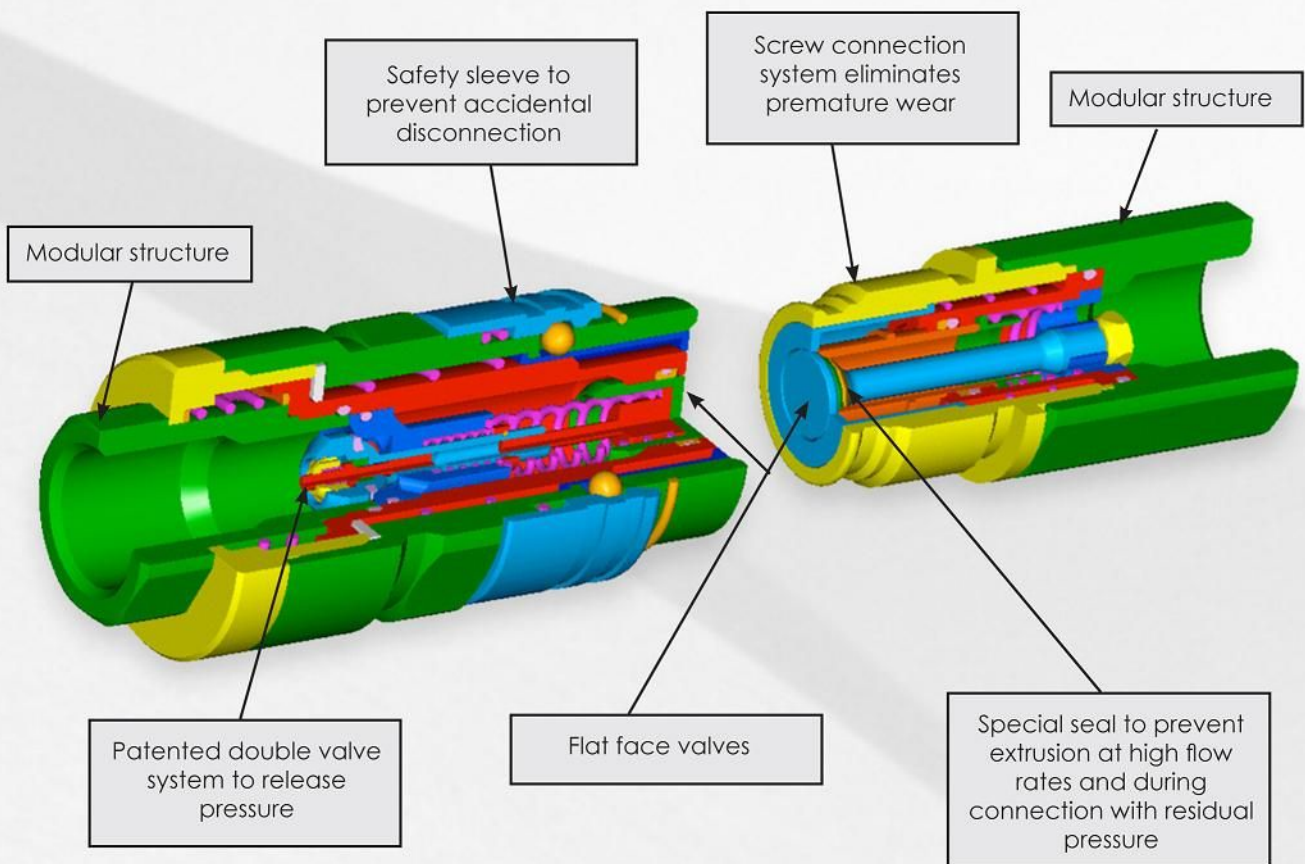

BENEFITS

- Flat face is easy to clean, helping to reduce the inclusion of contamination in the hydraulic circuit.
- Minimal fluid loss during connection / disconnection, reducing fluid loss to the environment.
- Minimal air inclusion during connection / disconnection, enhancing correct function of the circuit.
- Internal flow of valve design creates minimal pressure drop, maintaining circuit efficiency in the system.
- Internal pressure release valve system allows an easy connection with high internal residual pressure.
- The safety sleeve integrated in the connection system prevents the accidental disconnection.
- The modular design allows for broad range of port configurations.
- Good resistance at impulse pressures.
- Safe and simple to use.

HOW TO USE

- Before connecting clean the flat mating surface of coupling to avoid inclusion of contamination in the circuit.
- To couple align the female coupling to the male coupling, push the male and twist in one motion to catch the first thread on the female half and continue to thread together.
The screwing of the threads should be done by hand without the use of the tools for the first part of the connection.
The use of tools for the second part of connection can be necessary if there is high residual pressure in the circuit. Thread the mating halves until the sleeve lock clicks into position. This activates the safety lock and eliminates accidental disconnection of the coupling.
- To uncouple pull the locking sleeve towards the male coupling and unthread the connection.
The tighten is disengaged after one complete rotation of the coupler, continue to unthread until both halves disconnect.
If safety lock sleeve will not pull back rotate the male coupling to couple direction until the sleeve will pull back.

WARNING!

- Do not use the female coupling disconnected with impulse pressure at high frequency.
- Do not couple-uncouple with flow in the circuit. Connection only allowed with residual pressure.
- Do not couple-uncouple when the temperature inside of the circuit is higher than 80 °C (176 °F).
- Do not disconnect the coupling without pulling back the safety sleeve.
- When the couplings are disconnected, it is suggested to use the protection caps.
- It is important to limit contamination in the circuit to avoid compromising the function of the internal valves.

PERFORMANCE

Description	Size	ISO Size	Rated flow		Max. flow suggested		Connect ° torque		Disconnect ° torque		Spillage *
			l/min	GPM	l/min	GPM	Nm	lbf ft	Nm	lbf ft	
VP7	1/4	-	12	3,18	24	6,36	0,6	0,44	0,4	0,29	0,012
VP9P	3/8	-	23	6,10	46	12,19	0,8	0,59	0,5	0,37	0,040
VP13P	1/2	-	45	11,93	90	23,85	1,1	0,81	1,0	0,74	0,025
VP15P	5/8	-	74	19,61	148	39,22	1,1	0,81	1,0	0,74	0,033
VP17P	3/4	-	100	26,50	200	53,00	2,0	1,47	1,4	1,03	0,018
VP21P	1	-	189	50,09	378	100,17	2,2	1,62	1,8	1,33	0,060
VP30P	1-1/2	-	288	76,32	750	198,75	6,5	4,79	3,2	2,36	0,200

Description	Max. operating pressure						Burst pressure					
	Coupled		Male		Female		Coupled		Male		Female	
	MPa	psi	MPa	psi	MPa	psi	MPa	psi	MPa	psi	MPa	psi
VP7	60	8700	60	8700	42	6090	150	21750	150	21750	126	18270
VP9P	55	7975	55	7975	33	4785	140	20300	140	20300	100	14500
VP13P	55	7975	55	7975	33	4785	140	20300	140	20300	100	14500
VP15P	55	7975	55	7975	33	4785	140	20300	140	20300	100	14500
VP17P	50	7250	50	7250	33	4785	125	18125	125	18125	100	14500
VP21P	47	6815	47	6815	30	4350	120	17400	120	17400	80	11600
VP30P	40	5800	40	5800	27	3915	110	15950	110	15950	80	11600

Description	Max. residual pressure during connection						Max. residual pressure during disconnect	
	Male Female to drain		Female Male to drain		Male and Female			
	MPa	psi	MPa	psi	MPa	psi	MPa	psi
VP7	30	4350	30	4350	25	3625	25	3625
VP9P	25	3625	25	3625	25	3625	25	3625
VP13P	25	3625	25	3625	20	2900	20	2900
VP15P	25	3625	25	3625	20	2900	20	2900
VP17P	25	3625	25	3625	15	2175	15	2175
VP21P	25	3625	25	3625	15	2175	15	2175
VP30P	25	3625	25	3625	5	725	5	725

° Connect torque and disconnect torque without residual pressure. The torque increase to increasing of internal residual pressure.

* Spillage is an indicative value of the fluid loss per couple-uncouple cycle without residual pressure.

• Temperature range: Standard seals NBR, PUR, POM from -20 °C to +100 °C (from -4 °F to +212 °F).

• Note: VP7 has metal to metal sealing system in the internal valve of male and in the valve of female coupling.

• Tests:

- The couplings have been tested at max. operating pressure for 100'000 impulses in according with ISO 7241-2.

PRESSURE DROP

TESTS ESEGUITI IN CONFORMITA' A ISO 7241-2
 TESTS IN ACCORDANCE WITH ISO 7241-2

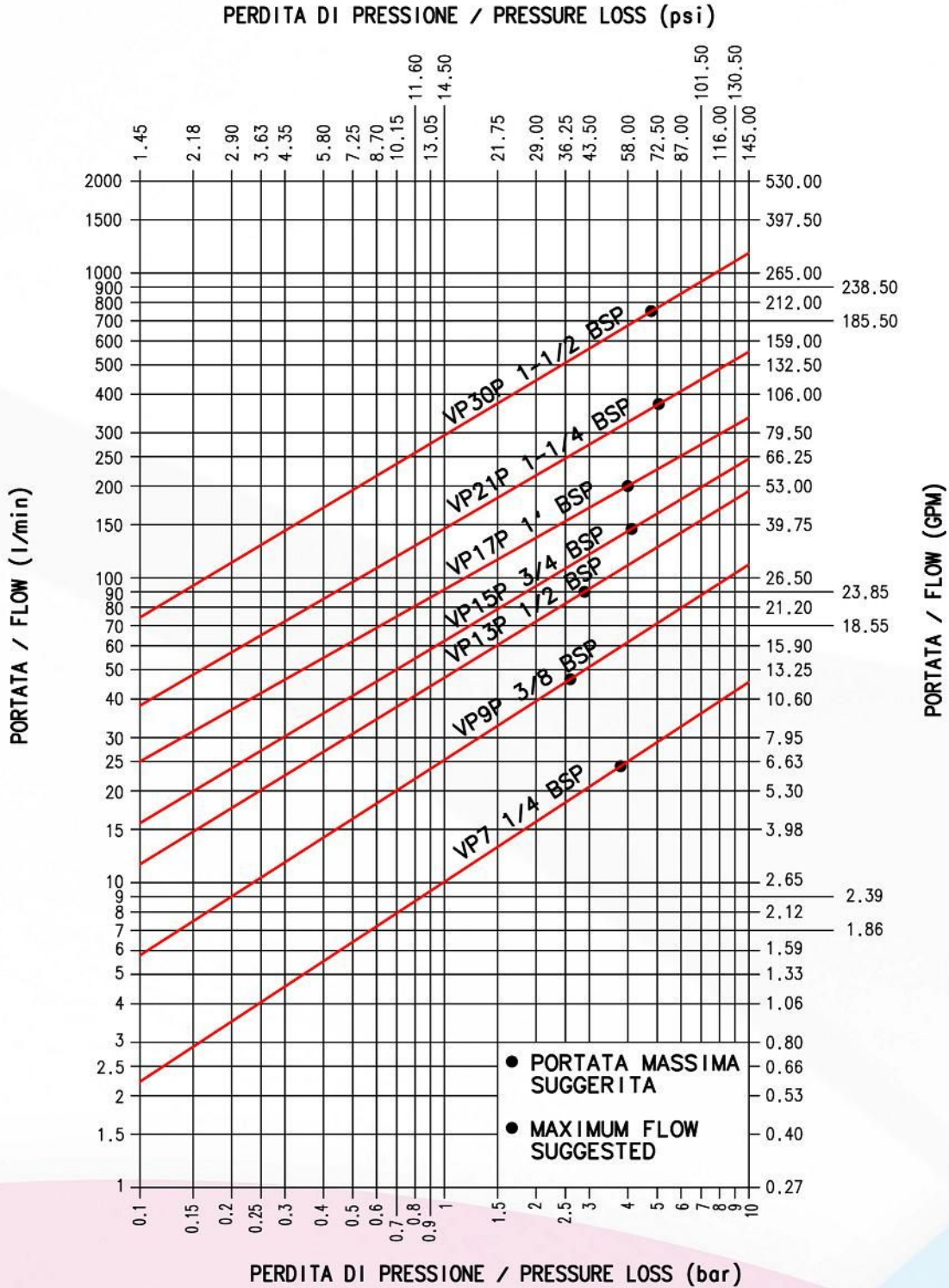

FLUIDO: OLIO ISO VG32
 TEMPERATURA: 40°C
 VISCOSITA': 28.8-35.2 mm²/s

FLUID: OIL ISO VG32
 TEMPERATURE: 40°C
 VISCOSITY: 28.8-35.2 mm²/s

OVERALL DIMENSIONS

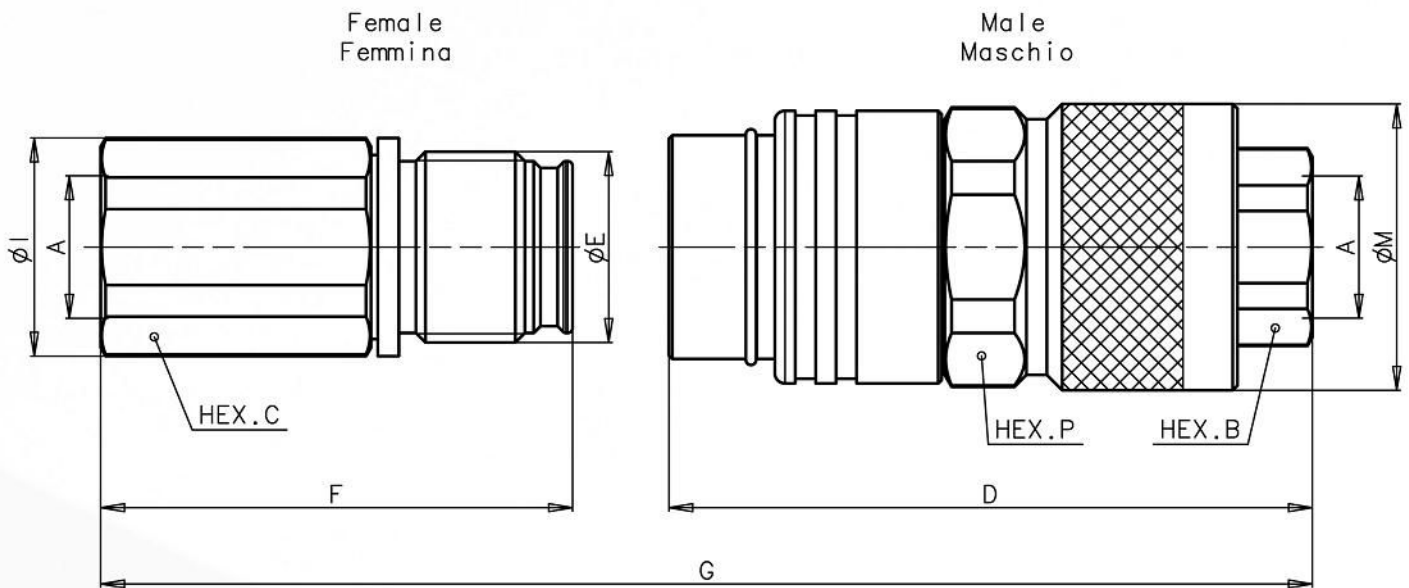

FEMALE BSPB THREAD (DIN 3852)

Description	A	Unit	B	C	D	E	F	G	I	M	P	Unit	Weight	
													Male	Female
VP7	1/4	mm	22	27	83,9	M24x2	52,8	125,2	29	35	32	Kg	0,393	0,160
1/4 BSP		Inch	0,87	1,06	3,30	-	2,08	4,93	1,14	1,38	1,26	Lb	0,87	0,35
VP9P	3/8	mm	27	30	94,5	M28x2	64,3	142,3	32	42	38	Kg	0,595	0,240
3/8 BSP		Inch	1,06	1,18	3,72	-	2,53	5,60	1,26	1,65	1,50	Lb	1,31	0,53
VP9P	1/2	mm	27	30	94,5	M28x2	69,3	147,3	32	42	38	Kg	0,575	0,245
1/2 BSP		Inch	1,06	1,18	3,72	-	2,73	5,80	1,26	1,65	1,50	Lb	1,27	0,54
VP13P	1/2	mm	36	36	110	M36x3	76,2	167,9	40	49	45	Kg	0,980	0,420
1/2 BSP		Inch	1,42	1,42	4,33	-	3,00	6,61	1,57	1,93	1,77	Lb	2,16	0,93
VP13P	3/4	mm	36	36	110	M36x3	83,2	174,9	40	49	45	Kg	0,945	0,440
3/4 BSP		Inch	1,42	1,42	4,33	-	3,28	6,89	1,57	1,93	1,77	Lb	2,08	0,97
VP15P	3/4	mm	36	41	110	M39x3	83,4	174,9	44,8	52	48	Kg	1,055	0,580
3/4 BSP		Inch	1,42	1,61	4,33	-	3,28	6,89	1,76	2,05	1,89	Lb	2,33	1,28
VP17P	3/4	mm	46	46	127,1	M45x3	96	200,5	49,8	60	55	Kg	1,635	0,955
3/4 BSP		Inch	1,81	1,81	5,00	-	3,78	7,89	1,96	2,36	2,17	Lb	3,60	2,11
VP17P	1	mm	46	46	127,1	M45x3	98	202,5	49,8	60	55	Kg	1,585	0,905
1 BSP		Inch	1,81	1,81	5,00	-	3,86	7,97	1,96	2,36	2,17	Lb	3,49	2,00
VP21P	1	mm	55	55	137	M55x3	104	213,8	59,8	76	70	Kg	2,610	1,495
1 BSP		Inch	2,17	2,17	5,39	-	4,09	8,42	2,35	2,99	2,76	Lb	5,75	3,30
VP21P	1-1/4	mm	55	55	137	M55x3	105	214,8	59,8	76	70	Kg	2,510	1,395
1-1/4 BSP		Inch	2,17	2,17	5,39	-	4,13	8,46	2,35	2,99	2,76	Lb	5,53	3,08
VP30P	1-1/4	mm	65	65	174,7	M72x4	132,2	271,3	85	94	85	Kg	5,220	3,030
1-1/4 BSP		Inch	2,56	2,56	6,88	-	5,20	10,68	3,35	3,70	3,35	Lb	11,51	6,68
VP30P	1-1/2	mm	65	65	174,7	M72x4	132,2	271,3	85	94	85	Kg	5,120	2,930
1-1/2 BSP		Inch	2,56	2,56	6,88	-	5,20	10,68	3,35	3,70	3,35	Lb	11,29	6,46

OVERALL DIMENSIONS

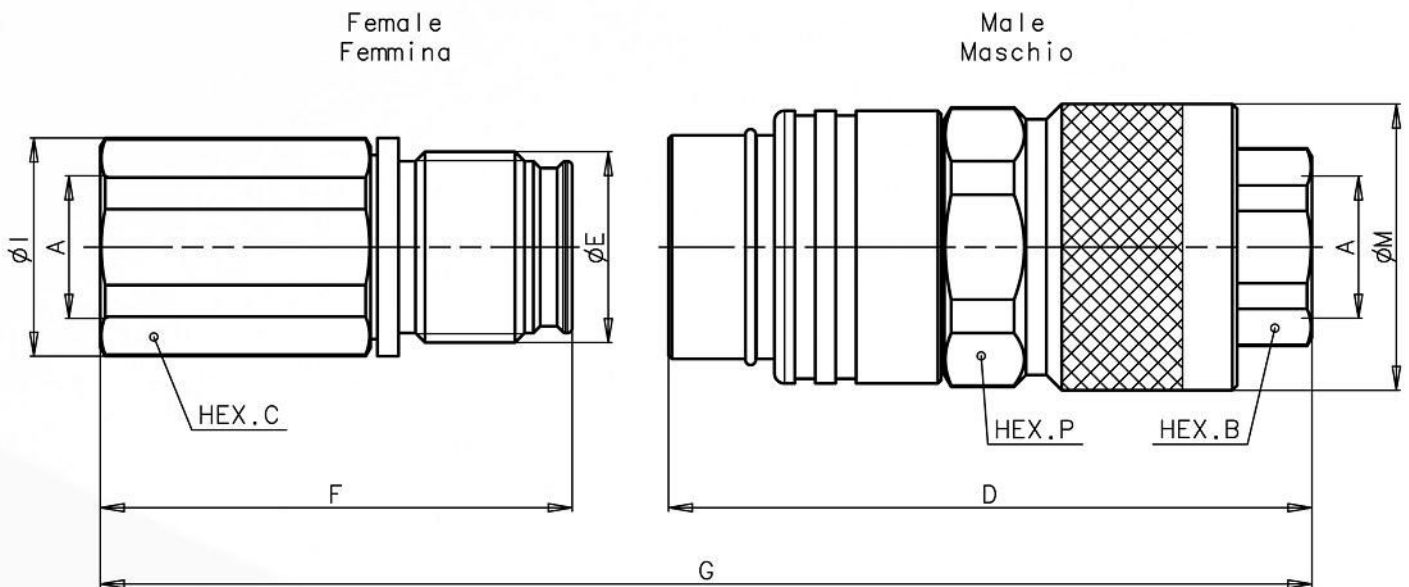

FEMALE NPT THREAD (ANSI B.1.20.3)

Description	A	Unit	B	C	D	E	F	G	I	M	P	Unit	Weight	
													Male	Female
VP7 1/4 NPT	1/4	mm Inch	22 0,87	27 1,06	85,3 3,36	M24x2 -	52,8 2,08	126,6 4,98	29 1,14	35 1,38	32 1,26	Kg lb	0,395 0,87	0,165 0,36
VP9P 3/8 NPT	3/8	mm Inch	27 1,06	30 1,18	94,5 3,72	M28x2 -	64,3 2,53	142,3 5,60	32 1,26	42 1,65	38 1,50	Kg lb	0,595 1,31	0,240 0,53
VP9P 1/2 NPT	1/2	mm Inch	27 1,06	30 1,18	94,5 3,72	M28x2 -	69,3 2,73	147,3 5,80	32 1,26	42 1,65	38 1,50	Kg lb	0,575 1,27	0,245 0,54
VP13P 1/2 NPT	1/2	mm Inch	36 1,42	36 1,42	110 4,33	M36x3 -	76,2 3,00	167,9 6,61	40 1,57	49 1,93	45 1,77	Kg lb	0,980 2,16	0,425 0,94
VP13P 3/4 NPT	3/4	mm Inch	36 1,42	36 1,42	110 4,33	M36x3 -	83,2 3,28	174,9 6,89	40 1,57	49 1,93	45 1,77	Kg lb	0,945 2,08	0,440 0,97
VP15P 3/4 NPT	3/4	mm Inch	36 1,42	41 1,61	110 4,33	M39x3 -	83,4 3,28	174,9 6,89	44,8 1,76	52 2,05	48 1,89	Kg lb	1,065 2,35	0,595 1,31
VP17P 3/4 NPT	3/4	mm Inch	46 1,81	46 1,81	127,1 5,00	M45x3 -	95 3,74	199,5 7,85	49,8 1,96	60 2,36	55 2,17	Kg lb	1,635 3,60	0,955 2,11
VP17P 1 NPT	1	mm Inch	46 1,81	46 1,81	127,1 5,00	M45x3 -	98 3,86	202,5 7,97	49,8 1,96	60 2,36	55 2,17	Kg lb	1,600 3,53	0,915 2,02
VP21P 1 NPT	1	mm Inch	55 2,17	55 2,17	137 5,39	M55x3 -	104 4,09	213,8 8,42	59,8 2,35	76 2,99	70 2,76	Kg lb	2,610 5,75	1,495 3,30
VP21P 1-1/4 NPT	1-1/4	mm Inch	55 2,17	55 2,17	137 5,39	M55x3 -	108,3 4,26	218,1 8,59	59,8 2,35	76 2,99	70 2,76	Kg lb	2,530 5,58	1,430 3,15
VP30P 1-1/4 NPT	1-1/4	mm Inch	65 2,56	65 2,56	174,7 6,88	M72x4 -	132,2 5,20	271,3 10,68	85 3,35	94 3,70	85 3,35	Kg lb	5,220 11,51	3,030 6,68
VP30P 1-1/2 NPT	1-1/2	mm Inch	65 2,56	65 2,56	174,7 6,88	M72x4 -	132,2 5,20	271,3 10,68	85 3,35	94 3,70	85 3,35	Kg lb	5,100 11,24	2,930 6,46

OVERALL DIMENSIONS

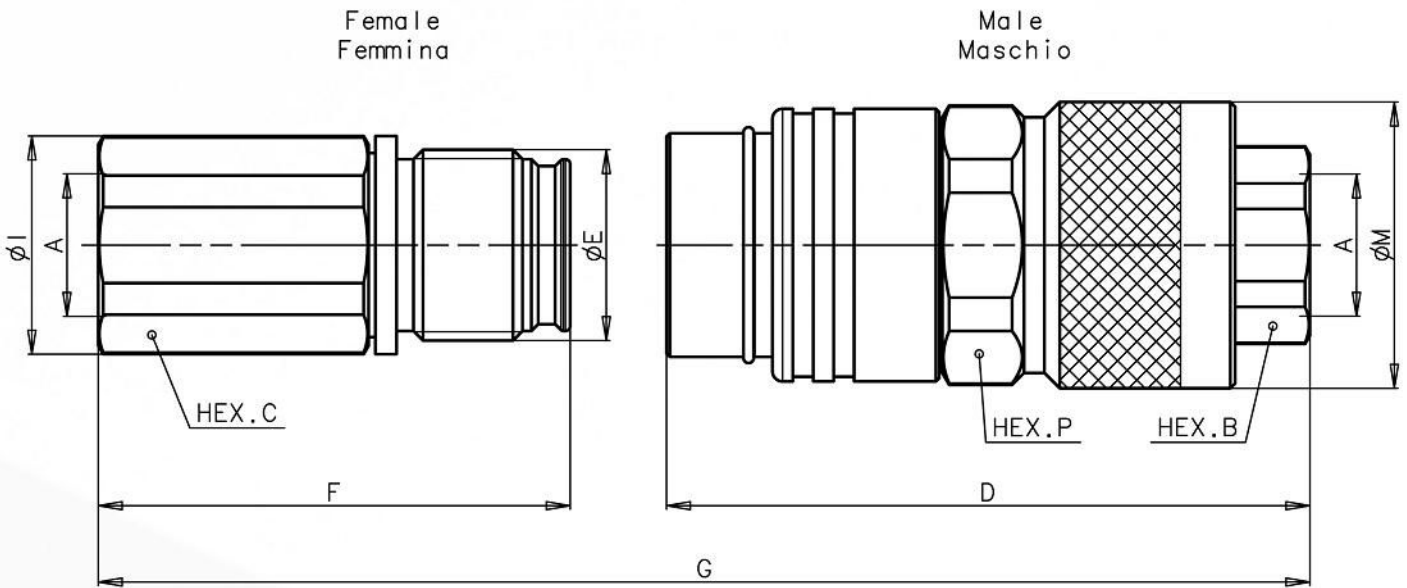

FEMALE SAE THREAD (SAE J1926-1)

Description	A	Unit	B	C	D	E	F	G	I	M	P	Unit	Weight	
													Male	Female
VP9P 3/8 SAE	9/16- 18UNF	mm Inch	27 1,06	30 1,18	94,5 3,72	M28x2 -	64,3 2,53	142,3 5,60	32 1,26	42 1,65	38 1,50	Kg lb	0,600 1,32	0,245 0,54
VP9P 1/2 SAE	3/4- 16UNF	mm Inch	27 1,06	30 1,18	94,5 3,72	M28x2 -	69,3 2,73	147,3 5,80	32 1,26	42 1,65	38 1,50	Kg lb	0,585 1,29	0,250 0,55
VP9P 5/8 SAE	7/8- 14UNF	mm Inch	30 1,18	30 1,18	104,5 4,11	M28x2 -	71,3 2,81	159,3 6,27	32 1,26	42 1,65	38 1,50	Kg lb	0,615 1,36	0,245 0,54
VP13P 5/8 SAE	7/8- 14UNF	mm Inch	36 1,42	36 1,42	110 4,33	M36x3 -	78,2 3,08	169,9 6,69	40 1,57	49 1,93	45 1,77	Kg lb	0,980 2,16	0,420 0,93
VP13P 3/4 SAE	1-1/16- 12UN	mm Inch	36 1,42	36 1,42	110 4,33	M36x3 -	83,2 3,28	174,9 6,89	40 1,57	49 1,93	45 1,77	Kg lb	0,930 2,05	0,430 0,95
VP15P 3/4 SAE	1-1/16- 12UN	mm Inch	36 1,42	41 1,61	110 4,33	M39x3 -	83,4 3,28	174,9 6,89	44,8 1,76	52 2,05	48 1,89	Kg lb	1,045 2,30	0,575 1,27
VP17P 3/4 SAE	1-1/16- 12UN	mm Inch	46 1,81	46 1,81	129,1 5,08	M45x3 -	98 3,86	204,5 8,05	49,8 1,96	60 2,36	55 2,17	Kg lb	1,635 3,60	0,955 2,11
VP17P 1 SAE	1-5/16- 12UN	mm Inch	46 1,81	46 1,81	127,1 5,00	M45x3 -	98 3,86	202,5 7,97	49,8 1,96	60 2,36	55 2,17	Kg lb	1,580 3,48	0,895 1,97
VP21P 1 SAE	1-5/16- 12UN	mm Inch	55 2,17	55 2,17	137 5,39	M55x3 -	104 4,09	213,8 8,42	59,8 2,35	76 2,99	70 2,76	Kg lb	2,610 5,75	1,495 3,30
VP21P 1-1/4 SAE	1-5/8- 12UN	mm Inch	55 2,17	55 2,17	137 5,39	M55x3 -	105 4,13	214,8 8,46	59,8 2,35	76 2,99	70 2,76	Kg lb	2,500 5,51	1,400 3,09
VP30P 1-1/4 SAE	1-5/8- 12UN	mm Inch	65 2,56	65 2,56	174,7 6,88	M72x4 -	132,2 5,20	271,3 10,68	85 3,35	94 3,70	85 3,35	Kg lb	5,220 11,51	3,030 6,68
VP30P 1-1/2 SAE	1-7/8- 12UN	mm Inch	65 2,56	65 2,56	174,7 6,88	M72x4 -	132,2 5,20	271,3 10,68	85 3,35	94 3,70	85 3,35	Kg lb	5,120 11,29	2,920 6,44